

HSCBs

Standard Family Code IR 6000 SERIES F

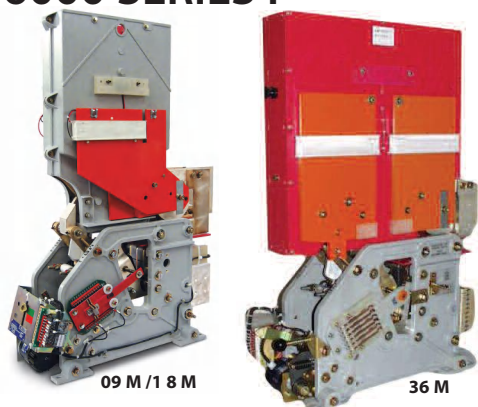

Description

DC single pole, magnetic blowout, trip free, air circuit breaker. The closing mechanism is motor-operated independent type while the holding mechanism is magnetic type, provided with holding coil or permanent magnet. The breaker is equipped with a direct acting over-current trip device, which may be either unidirectional or bi-directional. Reference standard IEC 61992.

		Family Code		
Voltage	Holding System	Thermal Current		
		3150 A	4000 A	5000 A
900 V	Holding Coil	IR 6030 FC 09M	IR 6040 FC 09M	IR 6050 FC 09M
	Permanent Magnet	IR 6030 FP 09M	IR 6040 FP 09M	IR 6050 FP 09M
1800 V	Holding Coil	IR 6030 FC 18M	IR 6040 FC 18M	IR 6050 FC 18M
	Permanent Magnet	IR 6030 FP 18M	IR 6040 FP 18M	IR 6050 FP 18M
3600 V	Holding Coil	IR 6030 FC 36M	IR 6040 FC 36M	IR 6050 FC 36M
	Permanent Magnet	IR 6030 FP 36M	IR 6040 FP 36M	IR 6050 FP 36M

Type	IR6000 F
Number of Poles	1 NO
Mounting Position	Vertical
Control Voltage Rating U_c [Vdc]	24 - 36 - 48 - 72 - 110 - 220 ¹
Auxiliary Contact Blocks	6 N.O. + 6 N.C.
Block Type	Reed or Sliding Contact
Arc chute Material	Ceramic
Main Contacts tips Material	AgSnO ₂
Arcing Contacts tips Material	AgW
Electric Diagram HC	42870233B
Electric Diagram PM	42870289B
Layout Drawing 900/1800V HC	42870405C
Layout Drawing 3600V HC	42870360C

¹ To be specified in order phase.

Electrical Characteristics	09M	18M	36M
Rated Operational Voltage U_{Ne} [Vdc] ¹	900	1800	3600
Max Operational Voltage [Vdc]	1000	2000	4000
Rated Insulation Voltage [Vdc]	2300	2300	3600
Conventional Free Air Thermal Current [A] at 40°C ²	3150 / 4000 / 5000 ¹		
Breaking Capacity [kA/ms]			
Rated Short Circuit	125 / 100	80 / 63	70 / 63
Duty F: Maximum Fault	125 / 0	80 / 0	70 / 0
Duty E: Maximum Energy	62.5 / 50	40 / 31.5	35 / 31.5
Duty D: Distant Fault	8 / 100	8 / 63	8 / 63
Peak arc voltage x U_{Ne} [\dot{U}_{arc}]	up to 4 x U_{Ne}		
Standard direct acting trip device [kA] ¹			
Setting Range 1		1 ÷ 1.6	
Setting Range 2		1.6 ÷ 2.6	
Setting Range 3		2.5 ÷ 4	
Setting Range 4		4 ÷ 6.4	
Setting Range 5		5.8 ÷ 9.3	
Setting Range 6		8 ÷ 13	
Setting Range 7		9.4 ÷ 15	
Setting Range 8		12.5 ÷ 20	
Blow Out Circuit Type	Coil		

² Device cabled according IEC 60947

Minimum clearances [mm] from ³ :							
Rated Operational Voltage [Vdc]	A ⁴	C	D	E	F	H	X
900	Metal Parts	1330	850	170			184
	Plastic Parts	1230	800	120			134
1800	Metal Parts	1330	850	170	545	232	673
	Plastic Parts	1230	800	120			134
3600	Metal Parts	1330	984	232			184
	Plastic Parts	1230	934	182			134

³ Reduced distances should be approved by M.S.

⁴ These quotes are referred to a 50 % surface opening grid.

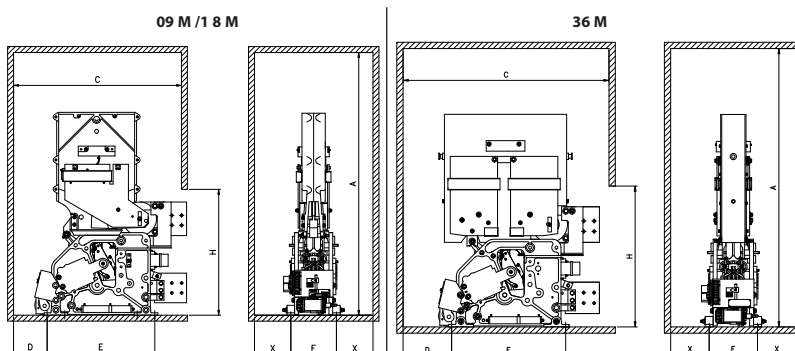

HSCBs

Standard Family Code IR 6060 and IR 6080 SERIES F

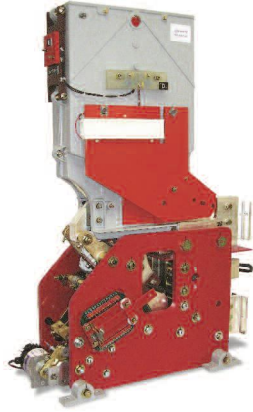

Description

DC single pole, magnetic blowout, trip free, air circuit breaker. The closing mechanism is motor-operated independent type while the holding mechanism is magnetic type, provided with holding coil or permanent magnet. The breaker is equipped with a direct acting over-current trip device, which may be either unidirectional or bi-directional. Reference standard IEC 61992.

Family Code			
Voltage	Holding System	Thermal Current	
		6000 A	8000 A
900 V	Holding Coil	IR 6060 FC 09M	IR 6080 FC 09M
	Permanent Magnet	IR 6060 FP 09M	IR 6080 FP 09M
1800 V	Holding Coil	IR 6060 FC 18M	IR 6080 FC 18M
	Permanent Magnet	IR 6060 FP 18M	IR 6080 FP 18M

Type	IR6060 / IR6080 F
Number of Poles	1 NO
Mounting Position	Vertical
Control Voltage Rating U_c [Vdc]	24 - 36 - 48 - 72 - 110 - 220 ¹
Auxiliary Contact Blocks	6 N.O. + 6 N.C.
Block Type	Reed or Sliding Contact
Arc chute Material	Ceramic
Main Contacts tips Material	AgSnO ₂
Arcing Contacts tips Material	AgW
Electric Diagram HC	42870233B
Electric Diagram PM	42870289B
Layout Drawing HC	42870504C

¹ To be specified in order phase.

Electrical Characteristics	09M	18M
Rated Operational Voltage U_{Ne} [V _{dc}] ¹	900	1800
Max Operational Voltage [V _{dc}]	1000	2000
Rated Insulation Voltage [V _{dc}]	2300	2300
Conventional Free Air Thermal Current [A] at 40°C ²	6000 / 8000 ¹	
Breaking Capacity [kA/ms]		
Rated Short Circuit	125 / 100	80 / 63
Duty F: Maximum Fault	125 / 0	80 / 0
Duty E: Maximum Energy	62.5 / 50	40 / 31.5
Duty D: Distant Fault	12 / 100	12 / 63
Peak arc voltage x U_{Ne} [\dot{U}_{arc}]	up to 4 x U_{Ne}	
Standard direct acting trip device [kA] ¹		
Setting Range 1	6 ÷ 12	
Setting Range 2	12 ÷ 24	
Blow Out Circuit Type	Coil	

² Device cabled according IEC 60947

Minimum clearances [mm] from ³ :								
Rated Operational Voltage [V _{dc}]	A ⁴	C	D	E	F	H	X	
900	Metal Parts	1330	840	170	545	269	673	184
	Plastic Parts	1230	790	120				134
1800	Metal Parts	1330	840	170				184
	Plastic Parts	1230	790	120				134

³ Reduced distances should be approved by M.S.

⁴ These quotes are referred to a 50 % surface opening grid.

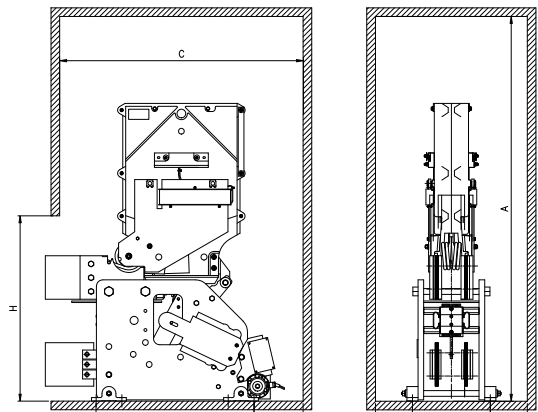

Mechanical Characteristics

Mechanical Endurance (cycles)	4x20000
Electrical durability [In @ Un]	4x200
Shock and Vibrations (IEC61373)	Cat.1 - Class B
Weight [kg]	160

Control Circuit

Control Voltage Range	0.7Uc ÷ 1.25Uc
Operated by	D.C. Motor
Holding closed by	Holding Coil or Permanent Magnet
Peak closing power and time [W x s]	400 x 0.01
Nominal closing power and time [W x s]	250 x 1.5

Holding Coil version

Nominal holding power @ 20°C [W]	50
Nominal opening power @ 20°C [W]	0
Controlled opening time [ms]	< 50

Permanent Magnet version

Nominal holding power @ 20°C [W]	0
Nominal opening power and time @ 20°C [W x s]	500 x 0.02
Controlled opening time [ms]	< 20

Auxiliary Contacts

Type	Reed Contacts (Vacuum Technology)
Voltage [V _{dc}]	24 / 36 / 48 / 72 / 110
Rated Current [A]	5
Maximum Breaking Power with Inductive Load τ=2ms [W]	120
Maximum Breaking Current with Inductive Load τ=2ms [A]	3
Maximum Breaking Voltage with Inductive Load τ=2ms [V]	250
Minimum let-through Current at 24Vdc [mA]	5

Environmental Conditions

Stock Temperature Range	-50°C ÷ +85°C
Operational Temperature Range	-30°C ÷ +70°C
Pollution Degree - Overvoltage Category (EN 50124-1)	PD3 - OV3
Clearance in air [mm]	32
Creepage distance [mm]	50.4
Comparative Tracking Index (CTI)	>600
Max Altitude without Performance Derating [m]	2000
Humidity ⁵	10 ÷ 95% RH

⁵ According to EN 50125-1

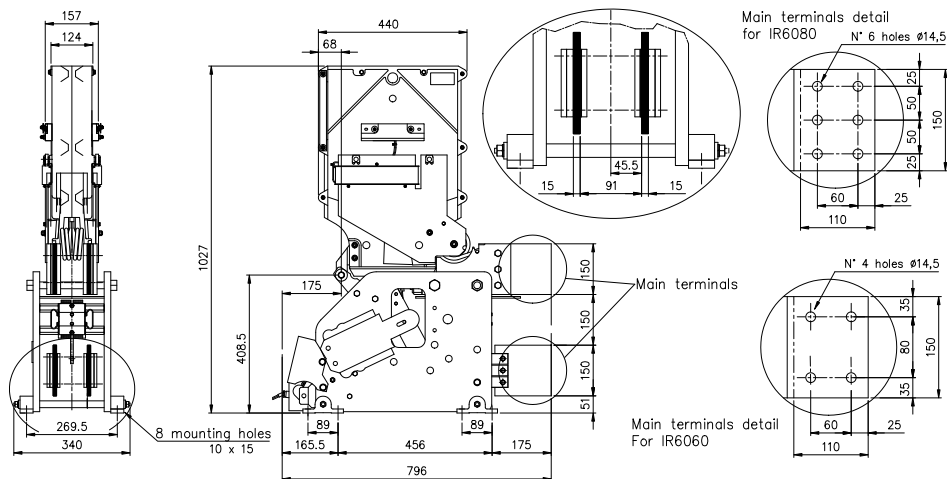

Mechanical Characteristics

Mechanical Endurance (cycles)	8x25000
Electrical durability [In @ Un]	4x200
Shock and Vibrations (IEC61373)	Cat.1 - Class B
Weight [kg] 09M and 18M / 36M	162 / 210

Control Circuit

Control Voltage Range	0.7Uc ÷ 1.25Uc
Operated by	D.C. Motor
Holding closed by	Holding Coil or Permanent Magnet
Peak closing power and time [W x s]	400 x 0.01
Nominal closing power and time [W x s]	250 x 1.5

Holding Coil version

Nominal holding power @ 20°C [W]	50
Nominal opening power @ 20°C [W]	0
Controlled opening time [ms]	< 50

Permanent Magnet version

Nominal holding power @ 20°C [W]	0
Nominal opening power and time @ 20°C [W x s]	500 x 0.02
Controlled opening time [ms]	< 20

Auxiliary Contacts

Type	Reed Contacts (Vacuum Technology)
Voltage [V _{dc}]	24 / 36 / 48 / 72 / 110
Rated Current [A]	5
Maximum Breaking Power with Inductive Load τ=2ms [W]	120
Maximum Breaking Current with Inductive Load τ=2ms [A]	3
Maximum Breaking Voltage with Inductive Load τ=2ms [V]	250
Minimum let-through Current at 24Vdc [mA]	5

Environmental Conditions

Stock Temperature Range	-50°C ÷ +85°C
Operational Temperature Range	-30°C ÷ +70°C
Pollution Degree - Overvoltage Category (EN 50124-1)	PD3 - OV3
Clearance in air [mm]	32
Creepage distance [mm]	50.4
Comparative Tracking Index (CTI)	>600
Max Altitude without Performance Derating [m]	2000
Humidity ⁵	10 ÷ 95% RH

⁵ According to EN 50125-1

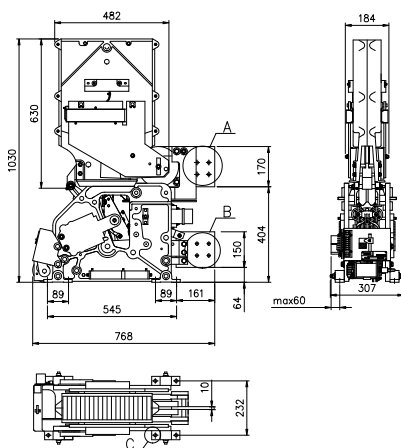

09 M / 18 M

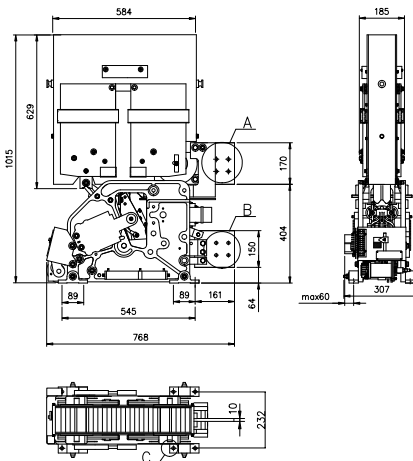
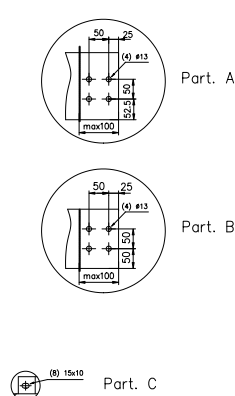

36 M

